

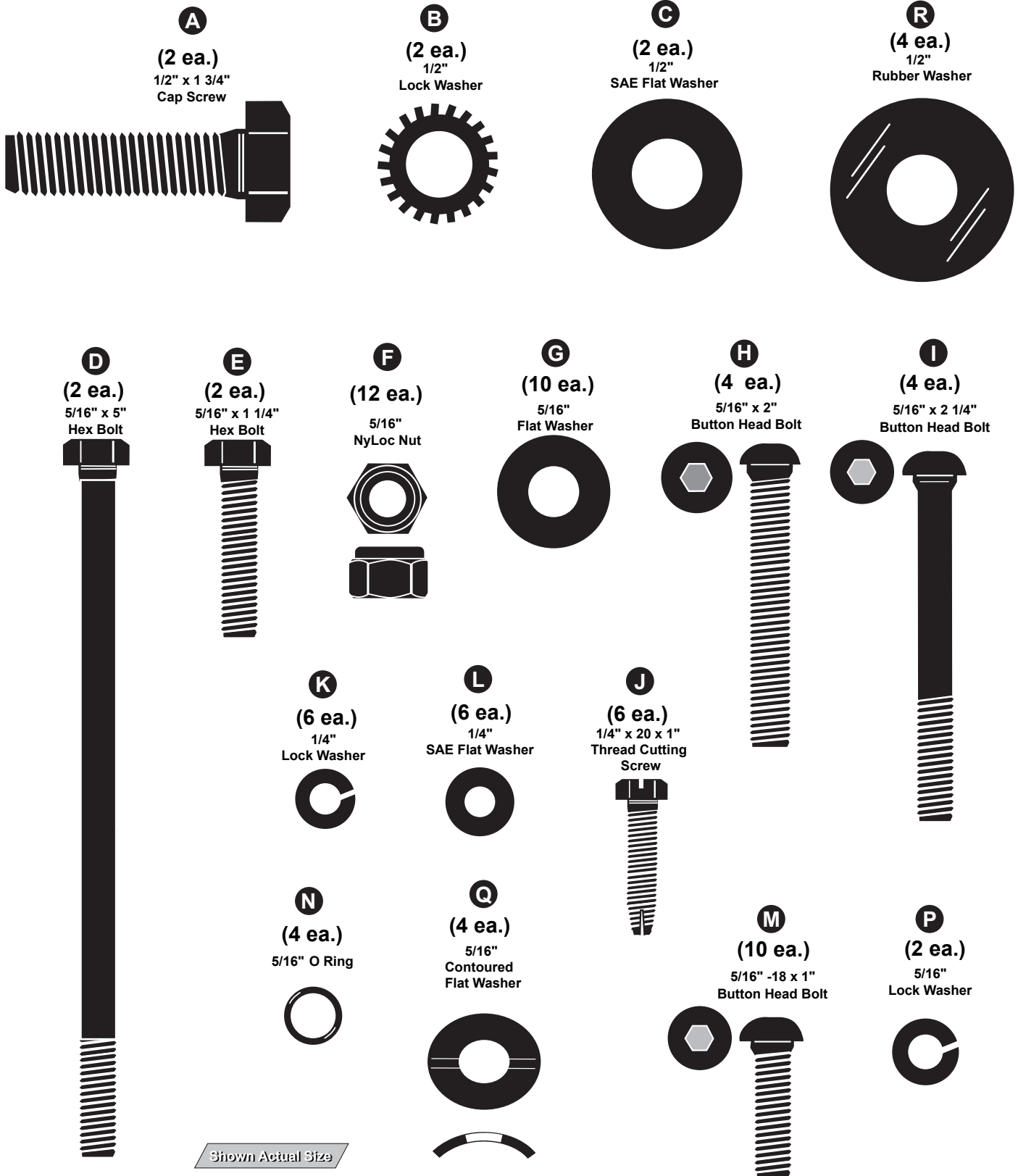

## HARDWARE KIT FOR CONGO CAGE ASSEMBLY



# ASSEMBLY & MOUNTING INSTRUCTIONS for CONGO CAGE

50331

50301

HARDWARE KIT #

50311

SEE PAGE 1

#1= Remove existing bolts from the upper half of the windshield hinge plates. Put a small bead of silicone inside and around the countersunk bolt holes in the existing windshield hinge plates. Attach front LEG MOUNT PLATES **01** with bolts **M**, and with lock washers **P**, as shown. Attach the rear LEG MOUNT PLATES, by removing the tail lights and sliding the rear LEG MOUNT PLATES **02** in behind tail lights and secure with thread cutting screws **J**, lock washers **K** and flat washers **L**. Next, at the upper hole of the rear LEG MOUNT PLATES **02**, drill a 5/16" hole through vehicle body. Secure with bolts **E**, flat washers **G**, and nyloc nuts **F**.

#2= Assemble the cage on the ground. Cover entire swaged joint surfaces with silicone sealant (see page 5). Assemble FRONT 'U' BAR **03** (it's the wider one) to FRONT LEGS **04** (they are the shorter ones) with button head bolts **H** and nyloc nut **F**. **IMPORTANT:** Orient bolts so that nut is in front of leg (hood side) and bolt head is behind leg (cab side).

#3= Now attach REAR 'U' BAR **05** to the REAR LEGS **06**, (see the detail drawing for the Rear Leg Hinge Joint), with button head bolts **H** and nyloc nuts **F**. Cover entire swaged joint surfaces with silicone sealant (see page 5).

#4= Find CROSS TUBES **07**. Cover entire swaged joint surfaces with silicone sealant (see page 5). Insert the CROSS TUBES into the cups on the FRONT and REAR U BARS. Secure with bolt **I**, then (on top side only) place O-rings **N** and contoured washer **Q**, with lock nuts **F**, (on the bottom side).

TIGHTEN UP ALL BOLTS.

THAT'S IT for the cage part. Lift the cage up onto the LEG MOUNT PLATES and secure with hex bolts **A**, rubber washers **R** (see attached detail: Front Leg Shock Absorbers), lock washers **B**, flat washers **C** for the front, and hinge bolts **D**, flat washers **G**, and nyloc nuts **F** for the rear.

SEE PAGE 4 TO ATTACH BASKET RACK.

#5= Align bolt holes of MOUNT PLATES **10** with holes of CLAMP PLATES **08** (inside rack cross beams **09**), and loosely attach MOUNT PLATES **10** with button head bolts **Q**, lock washers **R**, and flat washers **K** see DIAGRAM#1a. Position rack to desired location front to back and confirm position of rack side to side with equal distance from all end caps to mounting plates. After rack is centered, tighten bolts **Q**.

#6= With rack in it's final spot, attach MOUNT CLAMP STRAP **11**, around CROSS TUBES **07** and secure into MOUNT PLATE **10**, with bolts **T**, lock washers **U**, and flat washers **V**. Tighten all bolts.

THAT'S IT! YOUR INSTALLATION IS COMPLETE.

**NOTE:**

"Any time an overhead rack is mounted on a vehicle, there will be some incremental wind noise. In the vast majority of cases, the additional noise is subtle and not objectionable. Sometimes, for reasons we cannot explain, customers complain that the wind noise is intolerable. For these customers, we offer this Optional Wind Deflector. Be sure to specify the Wind Deflector part number that is appropriated for your Congo Cage.

**#60141** for CJ Congo Cage **#50301** and TJ Congo Cages **#50311** & **#50331**.

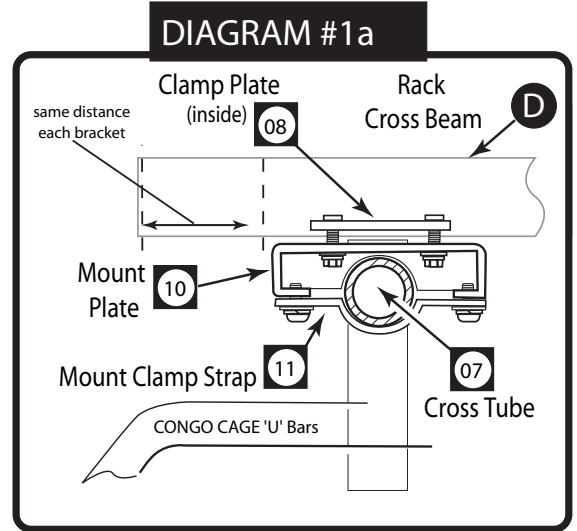
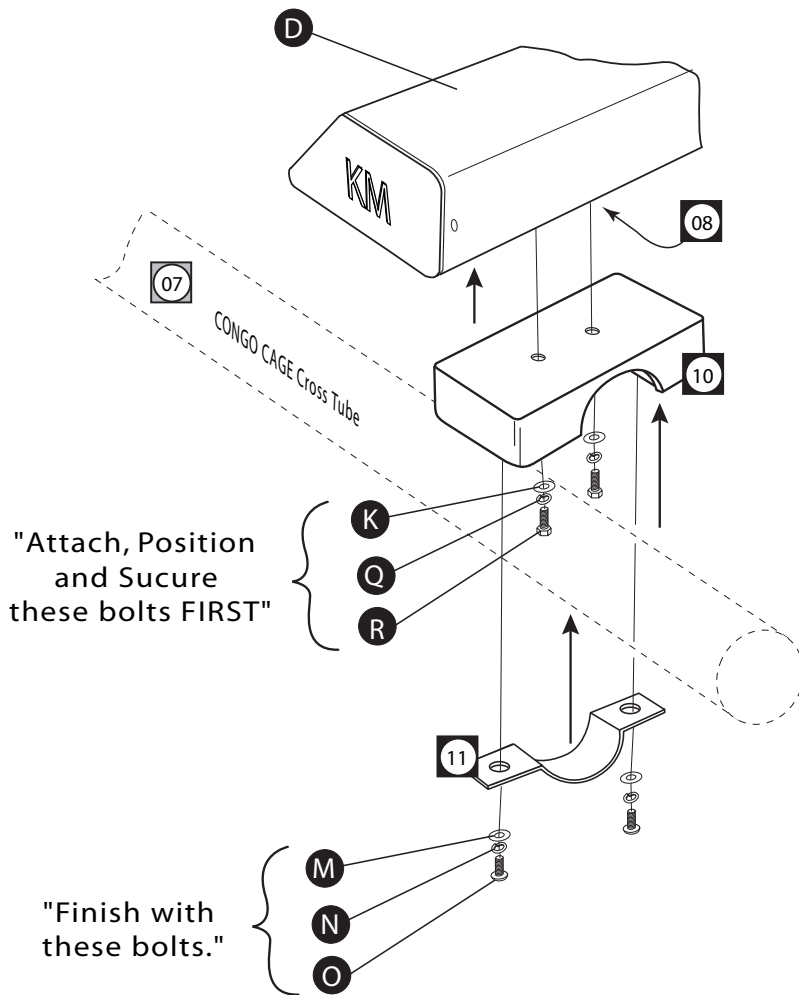

### HARDWARE KIT FOR CONGO CAGE MOUNT

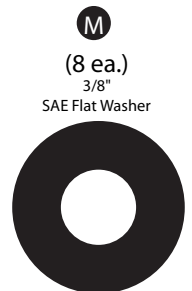
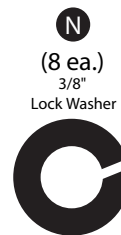
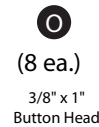
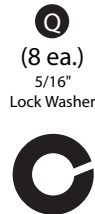

Shown Actual Size

### DETAIL: Front Leg Shock Absorbers

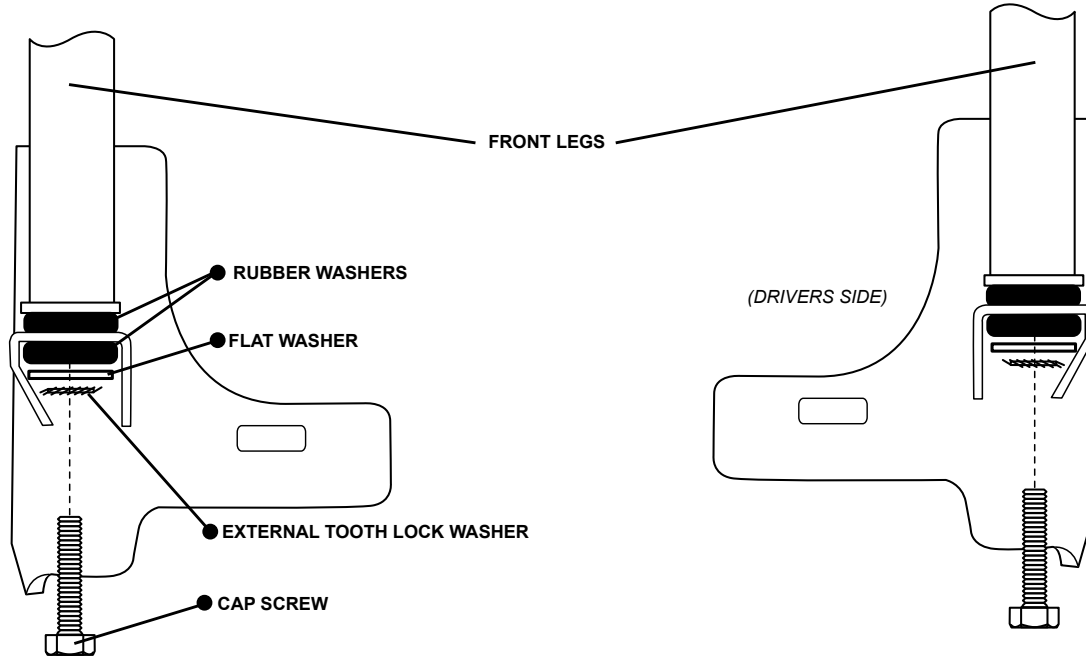

( TIGHTEN DOWN TO COMPRESS RUBBER TO 1/8" )

### DETAIL: Seal swage joints:

(WITHOUT SEALANT)

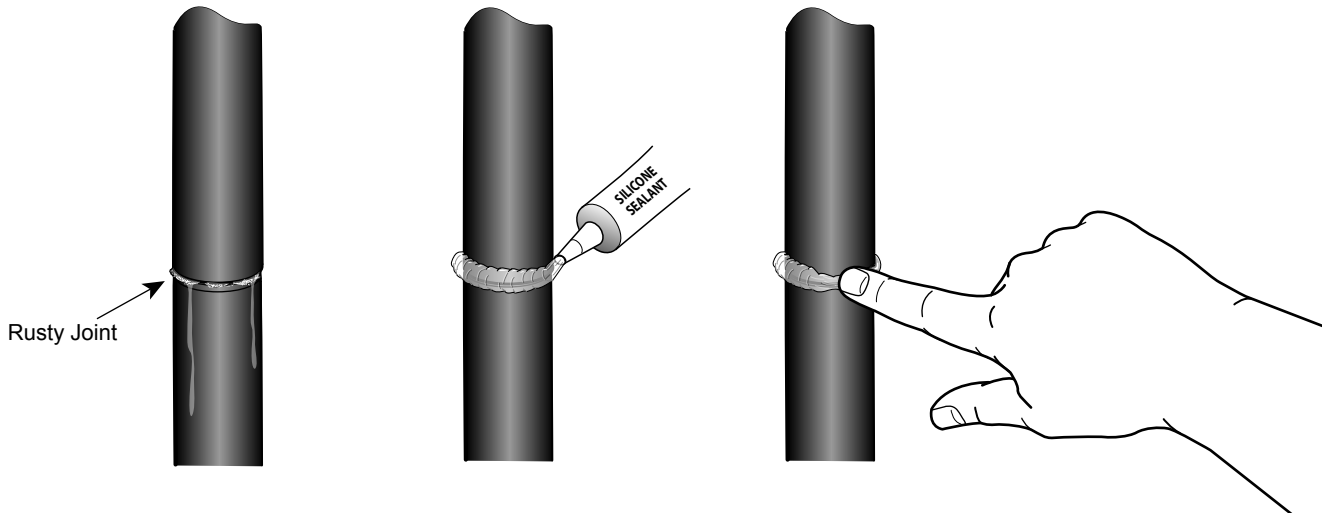

Apply a healthy air tight bead of silicone around **every** swaged joint to prevent moisture from leaking into and out of the joint. If this is not done properly, the inside surface of the tubes can rust and rusty water can leak out. Maintain this joint seal throughout the life of your rack.

Tighten down all nuts & bolts and **THAT'S IT!** You are now ready to use your rack.

**NOTE:** When raising Congo Cage to install or remove top, DO NOT rotate the Cage completely back as this will spring the rear hinge and/or damage the body of your jeep. Rotate only to the extent necessary.

Hold the Congo Cage in the raised position by inserting the two support rods (provided) into the hole of the front bracket and the hole in the bottom of the front leg.

**SUPPORT RODS PROVIDED**

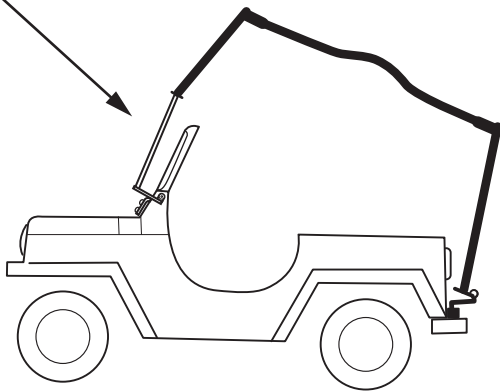

**YES**

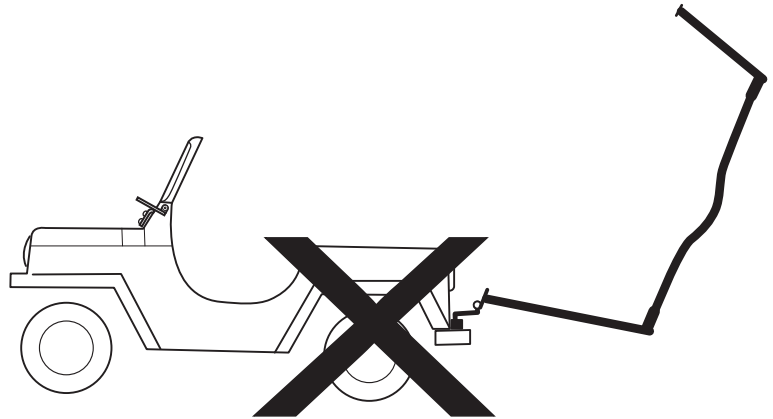

**NO**